



DOMED CEILING ATTACHMENT WITH SLOT

18th Edition Amendment 2:2022 compliant.

Architectural ceiling attachment, manufactured from bright nickel-plated brass, with integral slot – designed to provide a sleek, aesthetic fastening to the soffit whilst offering low visual impact.

The attachment can be fitted directly to a ceiling or mounted to a fixture and used in conjunction with the Zip-Clip range of architectural supports to build a complete wire rope suspension system.

AVAILABILITY

Product code: **ACSL0T**

Safe working load (SWL): 15 kg.

The two-part attachment consists of a male externally threaded base plate and an internally threaded dome cover to encapsulate a wire support stop end.

Slot in the dome cover allows rotation of the wire rope through an angle of up to 60 degrees (maximum).

Note: Fixings are not supplied. Suitability of the fixing is the responsibility of the installing contractor.

WIRE

Galvanised mild steel electro-galvanised wire rope, 1960 N/mm² grade, 7×7 IWRC construction, manufactured to BS EN 12385.

INSTALLATION

1. Disassemble the base plate by turning anti-clockwise.
2. Fix base plate to ceiling using desired fixing:
 - Concrete screw
 - Plug and screw
 - Wood screw
3. Ensure wire rope is correctly set inside the dome cover.
4. Screw the dome cover onto the base plate by turning clockwise.
5. Ensure the dome cover is secured.



Base plate and dome cover marry together to form one complete fitting with the same diameter.

DIMENSIONS

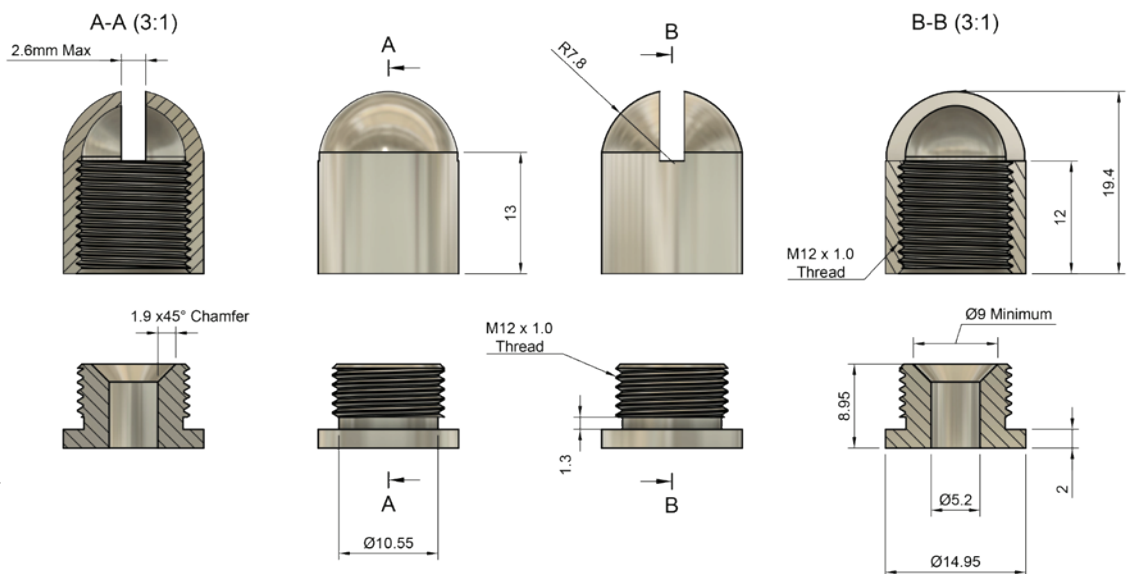

All dimensions in mm.
Manufactured from brass with a bright nickel plating finish.